

A Practical Approach to Refillable Kegs - Quality, Safety, and Maintenance



Steve Bradt

Regional Sales Manager



Are you looking inside your kegs?

Many brewers don't
and we're going show
why that's a problem -
for them and for the
Industry

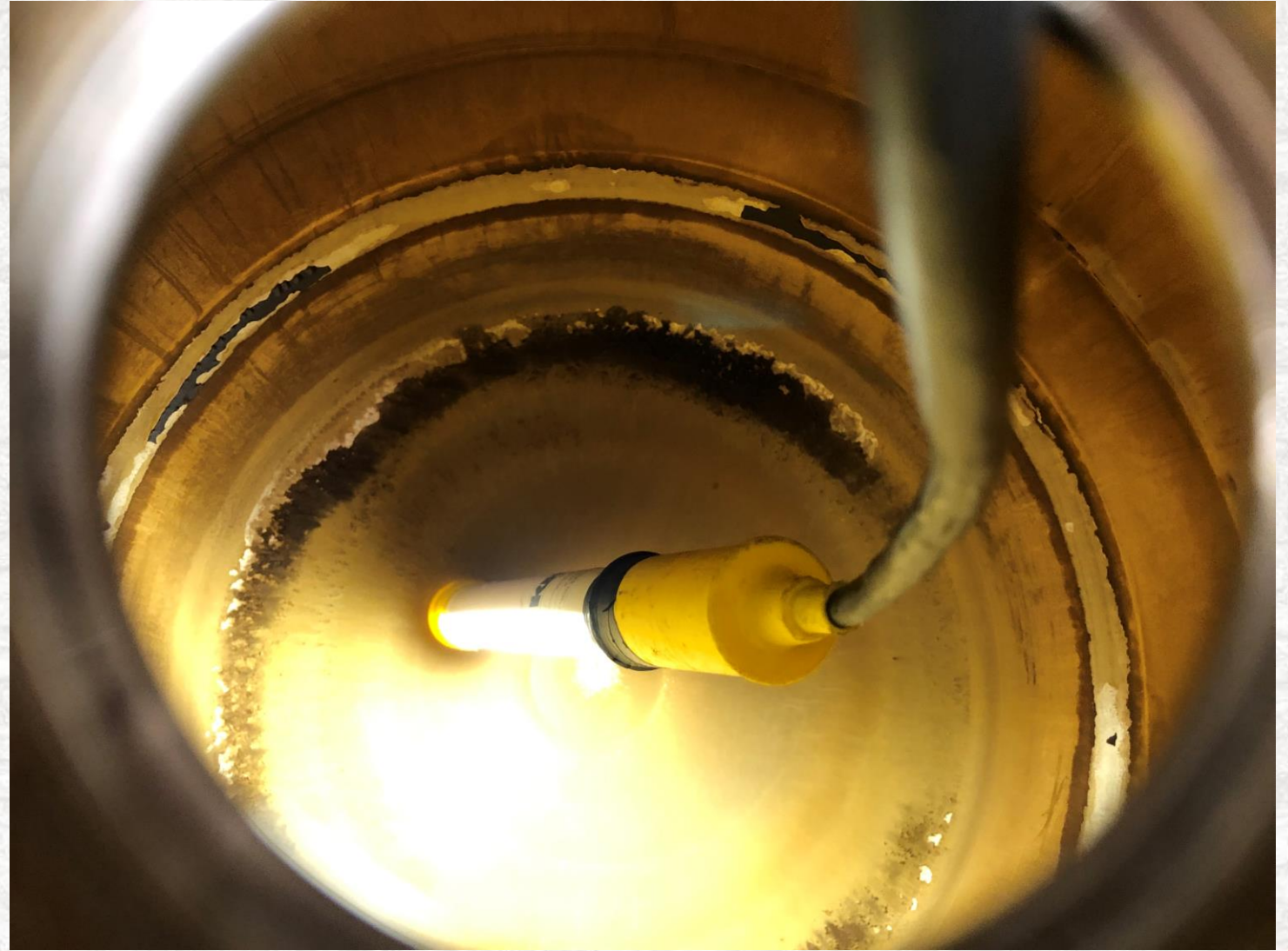

The Challenge:

A safe, successful and high quality draught packaging program requires buy-in from many departments within the brewery – Operations, Production, Packaging, Quality, and Maintenance. It also benefits from participation from staff outside of the brewery like Sales, Delivery and Draught-Tech staff who can provide point-of sale troubleshooting.

In order for those team members to be safe and successful, they must be equipped with:

- Knowledge of Best Practices
- Proactive maintenance programs
- Proper training and well developed SOPs
- Motivation and encouragement to be fully engaged

Purchasing new or used refillable kegs

- Order your kegs thoughtfully
- Some considerations:
 - Ask keg and spear suppliers for their process for passivation of kegs and spears.
 - Request information on pressure and drop tests
 - Will your kegs include rupture disks?
 - Design features of chimes – metal gauge, drain holes, handle design etc.
 - Specify neck and valve styles and manufacturers
 - What sizes are popular in your market

For further information on setting standards for your new kegs, see the Brewers Association's "[Performance Guidelines for Refillable Kegs](https://www.brewersassociation.org/educational-publications/refillable-beer-keg-guidelines/)" at <https://www.brewersassociation.org/educational-publications/refillable-beer-keg-guidelines/>

Components of the package



Keg Shell - various sizes and configurations



Keg Spear (Valve and down-tube)
All the moving parts



TOP VIEW

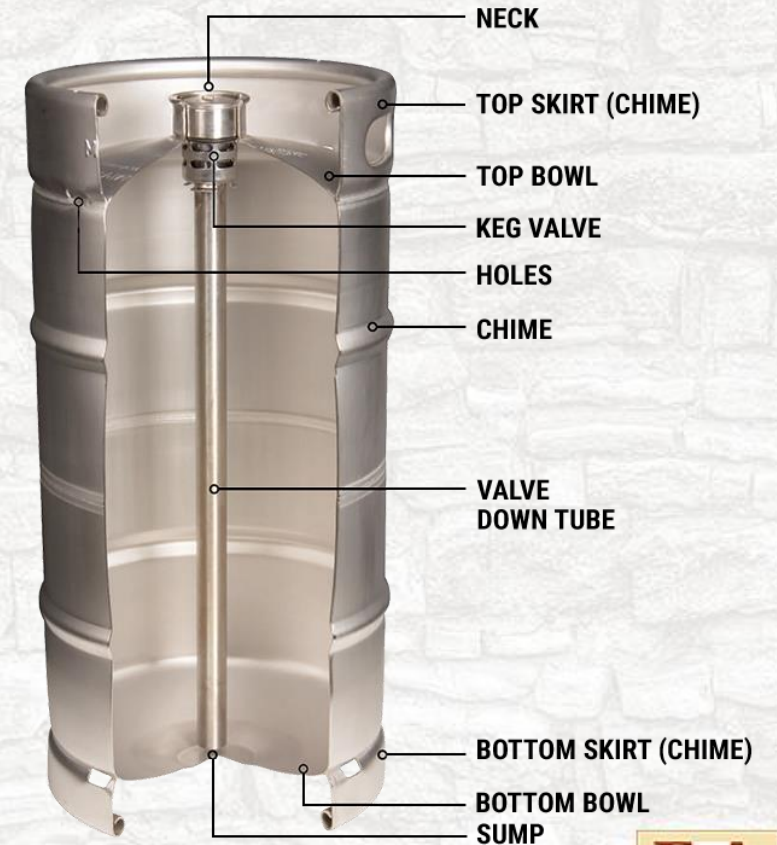

Damaged shells result in quality, cleaning and safety issues



Bent Chime

Poor centering on keg washers, sharp edges, unstable, and likely to tip. May cause equipment damage and employee injuries.



Dented Sump

Interferes with cleaning flow. May cause spear to impact the bottom of the keg.



Bent Neck

Misdirection of cleaning flow. Damage to valves and cleaning equipment due to misalignment.

Kegs over-pressurized from freezing or overfilling

Before



Standard gap between top of neck and top of chime is 8.5 mm \pm 1.5

After



The neck should never sit higher than the keg chime

Kegs over-pressurized from freezing or overfilling

Before

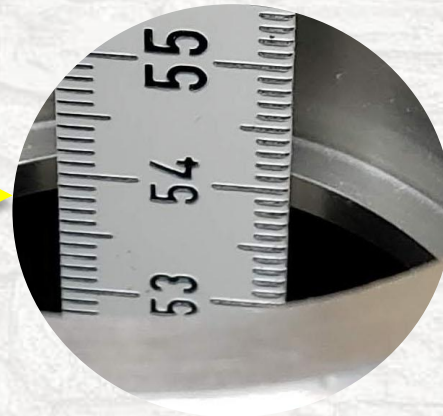

After

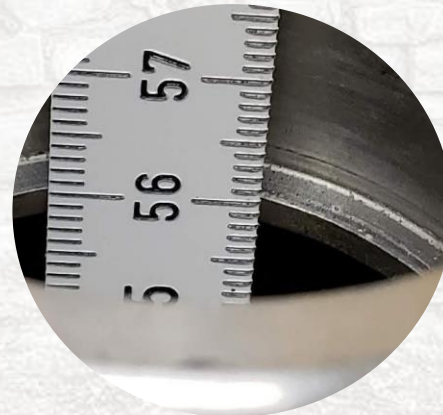

Measurable increase
to the internal
dimensions of the keg

Spears Around the World

Flat		Well			Combi	Soft
A-System	G-System	S-System	D-System	U-System	M-System	L-System



RS - A S

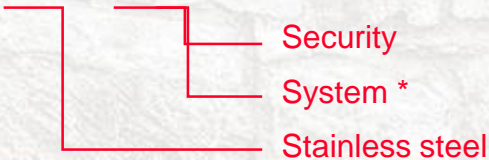

- * A-System = Alumasc
- * G-System = Grundy
- * S-System = Sankey
- * D-System = Draft System

- * U-System = Universal Equipment Company
- * M-System = Micro Matic
- * L-System = Soft Drink (Limonade)

Two Varieties of D System Valve*

Ball Beer Valve



Poppet Beer Valve



*Note that all internal components are unique to their valve type and manufacturer

D System Spear Safety Features

- Drop-in spears: Squared “ears” on body fit in the Z-slots in keg neck (fig. 1)
- Drop-in spears: Double Circlip, safe until tampered-with or reused
- Threaded spears: Safety Clip (fig. 2)
- Pressure Relief Safety Feature for untapped kegs: both poppet-type and color coded ball-type CO₂ Valves (fig.3)

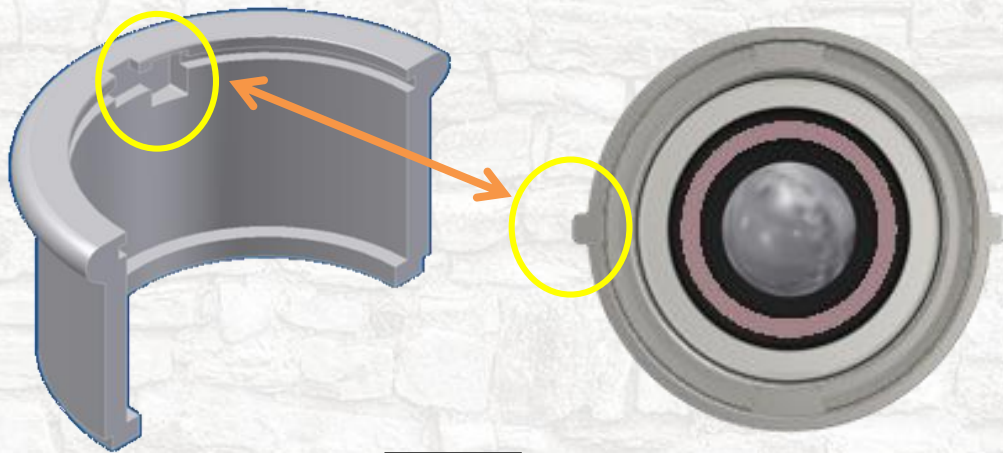

Fig. 1

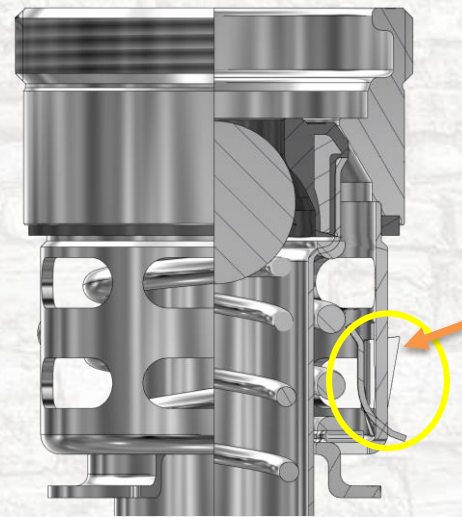

Fig. 2



Fig. 3

Three Keg Neck Styles

Two-eared Drop-in Neck



Secured by a
Double Circlip

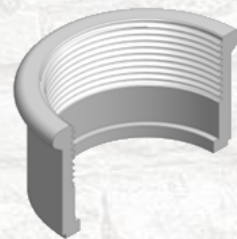
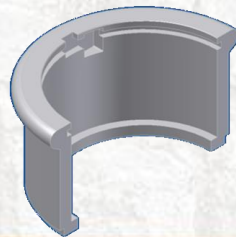

14 tpi Threaded
Neck

SOS/Euro Style Neck



Secured by a
Single Circlip

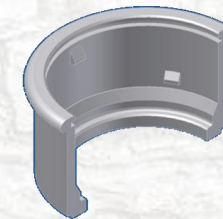

Identification of Parts

Note that parts configurations vary between spear models and manufacturers. Always check with the manufacturer of your keg spears to obtain appropriate service parts & tools for your specific application

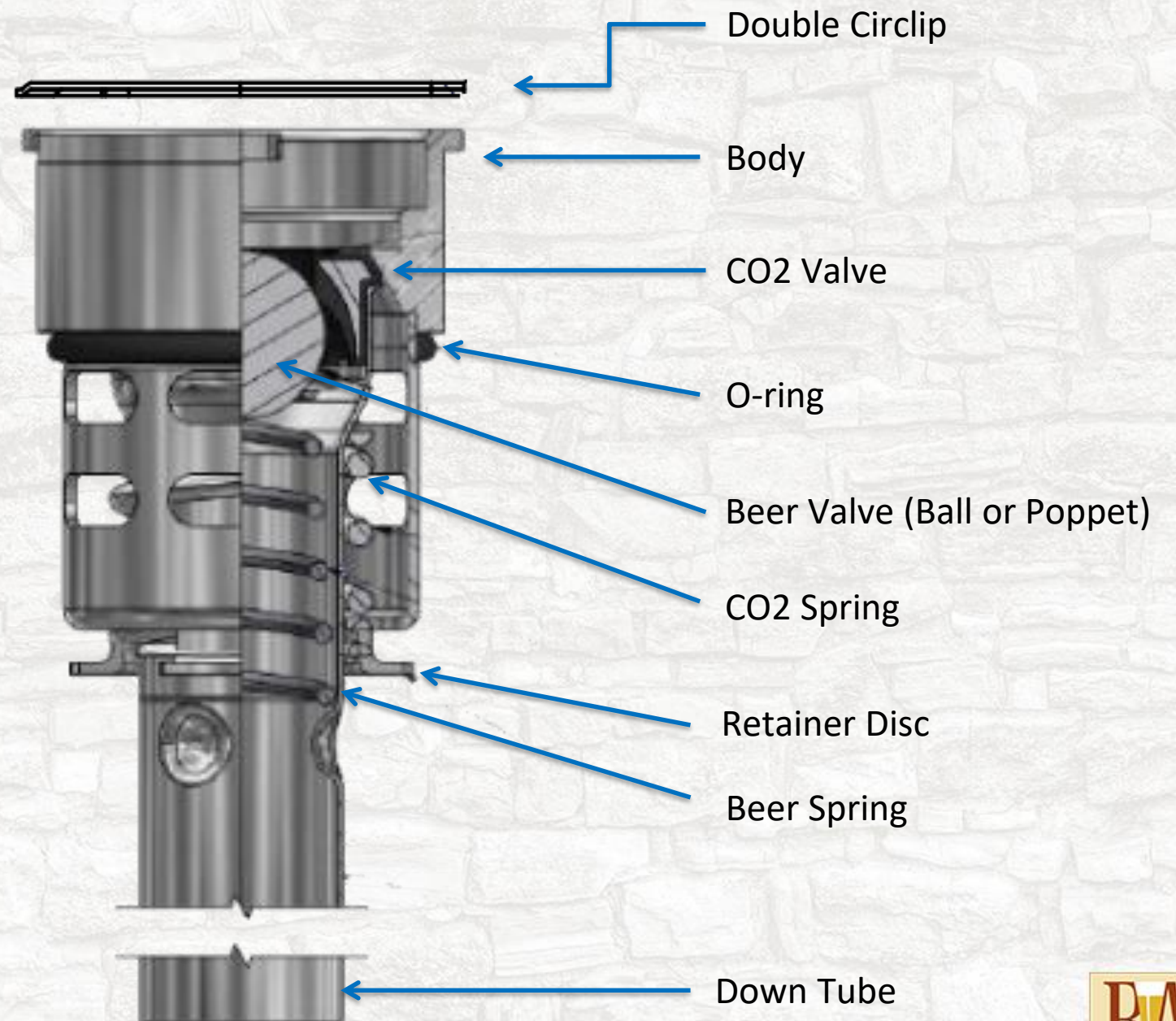

Spear Length, Critical to Function

Filling and Dispensing

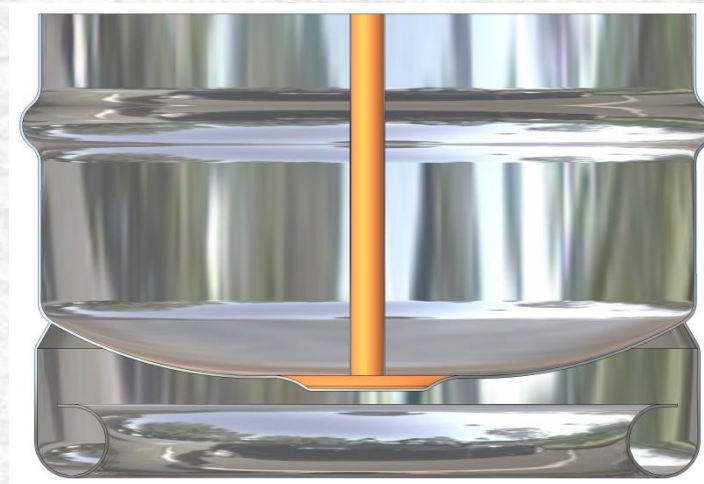
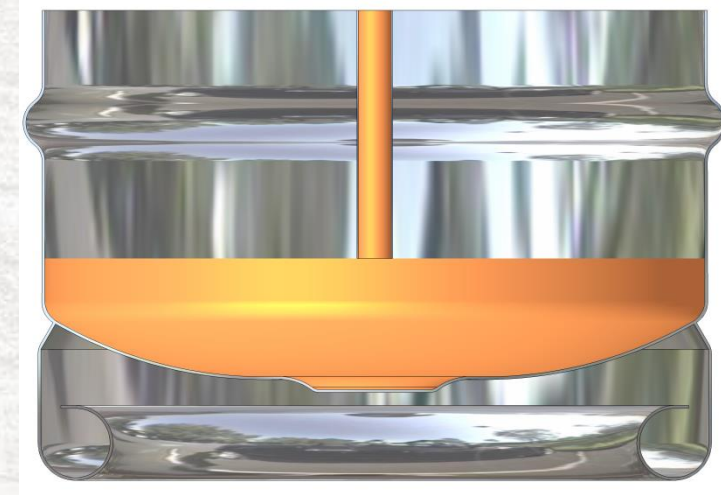
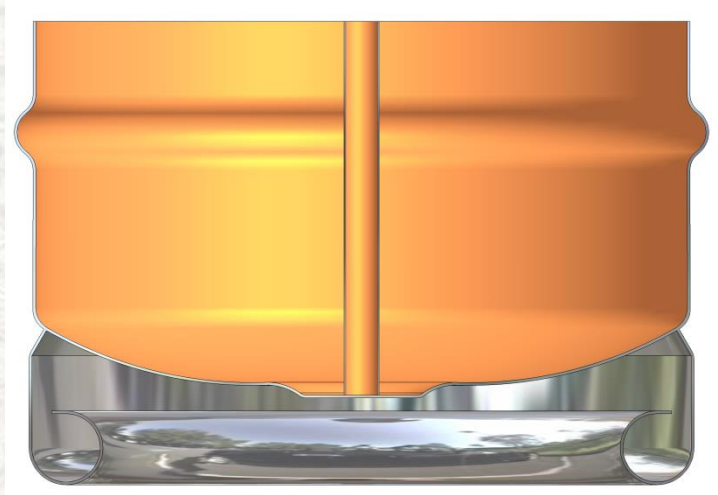

Spear Length, Critical to Function

Cleaning

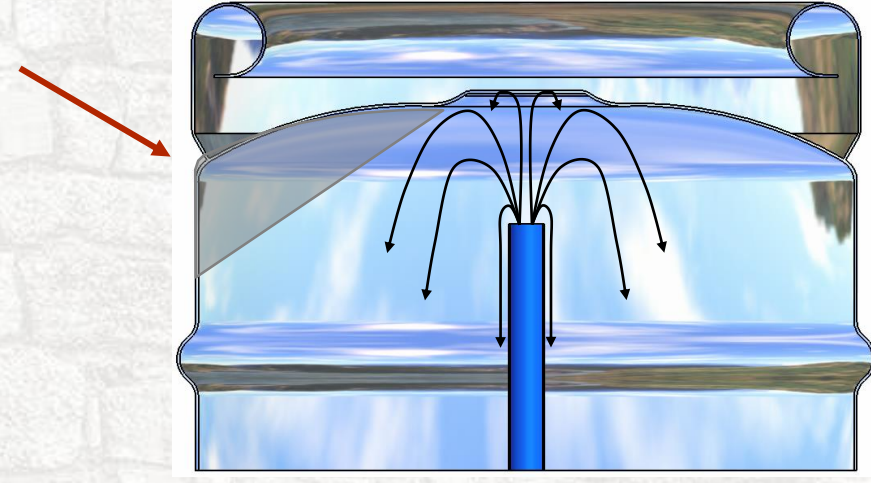
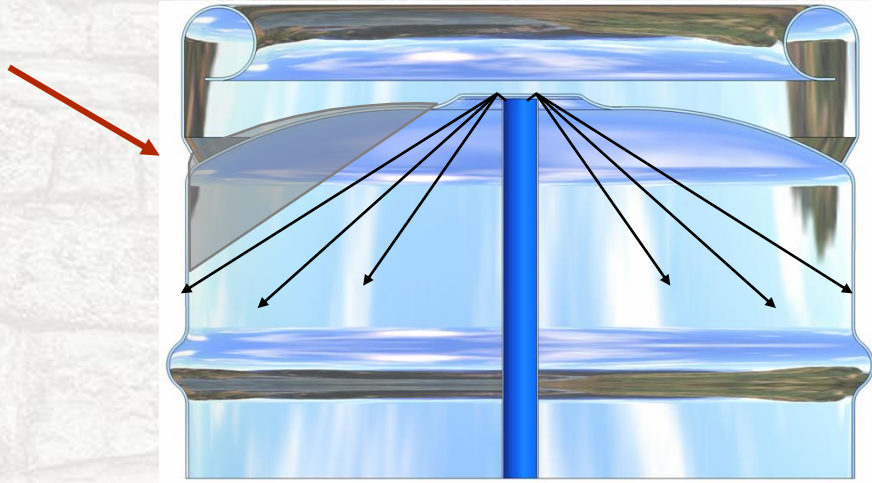

Improperly sized spears can result in cleaning shadows

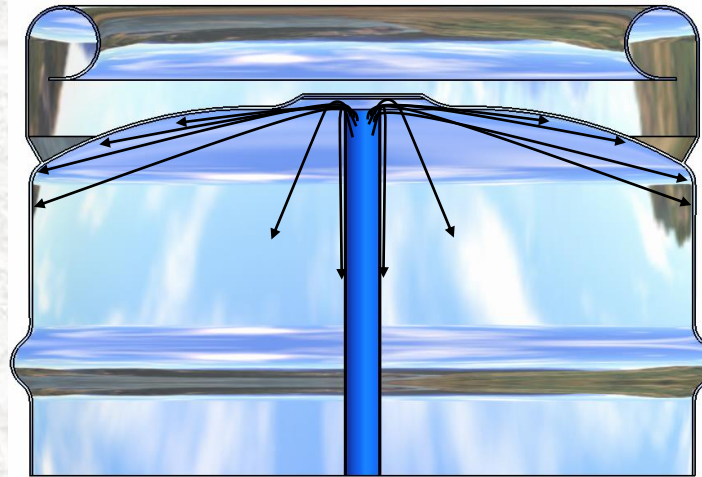

Determining Correct Spear Length

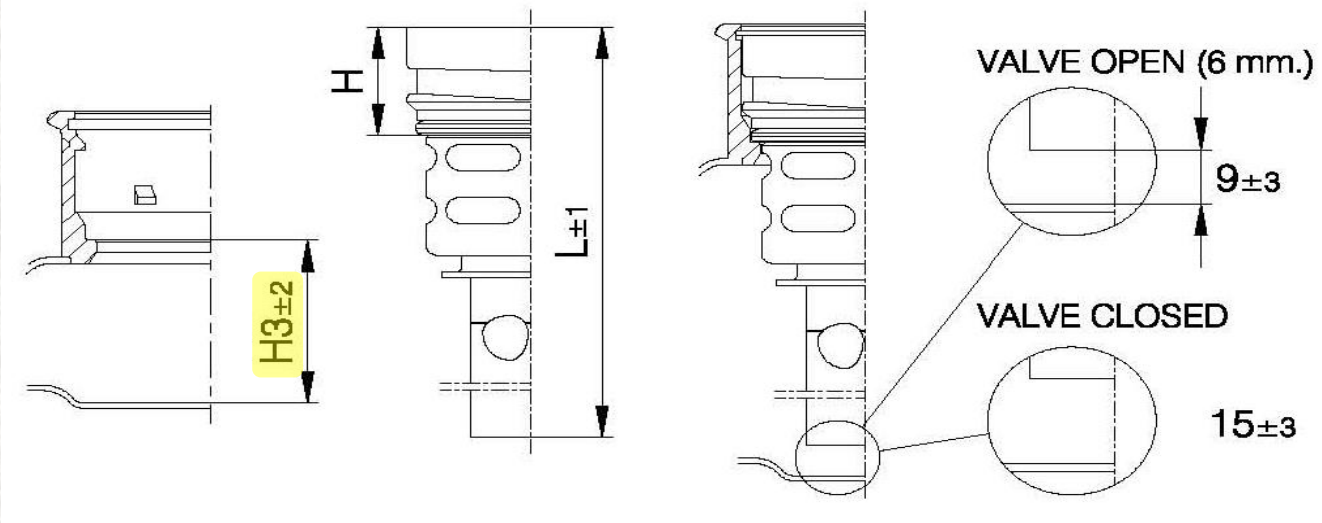

- Drop-in, SOS Type Necks:
 $H3 + 12\text{mm} = L$
- 14tpi Threaded Necks:
 $H3 + 15\text{mm} = L$



$H3 = 540 \text{ mm}$

Causes for Valve Failure: Abuse!

- Keg Coupler (aka Tavern Head)
 - Damaged
 - Careless operator
- Washer/Filling Line Interface
 - Damaged
 - Poor design of probe
 - Keg neck “bent”
 - Keg neck poorly centered
 - Foreign objects
- UV Light Exposure
 - Avoid storing kegs with the valves exposed to sunlight
 - UV causes deterioration and delamination of valves
- Overfilling
- Old Age
 - This can be avoided with a good preventative maintenance program to replace valves *BEFORE* they fail!

**Don't
Overdo it!**

- **Excessive Temperature & Chemical Exposure**
 - Note limits on times, temperatures and concentrations in the Micro Matic warranty below.
 - These are maximum levels, not recommendations. You should consult with your chemical supplier and regularly inspect your kegs to determine the best levels for effectively cleaning your kegs.
- **Micro Matic Product Warranty**
 - Function, 2 years; Rubber parts, 2 years; Metal parts, 5 years
 - Following guidelines:
 1. Maximum steam temperature, 135°C (275°F), max 2 minutes
 2. Maximum acid temperature 80°C (176°F), max 10 minutes; valid for =/<3% solution of Phosphoric, Nitric/Phos blend, Citric acids
 3. Maximum alkali temperature 80°C (176°F), max 10 minutes for =/<3% solution

Kegs Require Headspace

A ½ Bbl keg filled at 4°C will increase in volume by 140 ml at 15° C, 200 ml at 20° C and 450 ml by 40° C.

Without proper headspace, the extra liquid volume has nowhere to go, and pressures inside the keg can reach or **significantly exceed 10 bar in ½ bbls and 13 bar in sixth bbls**, causing damage to kegs and valves

Overfilled Kegs

Volume Increase in a ½ Bbl Keg by Thermal Expansion

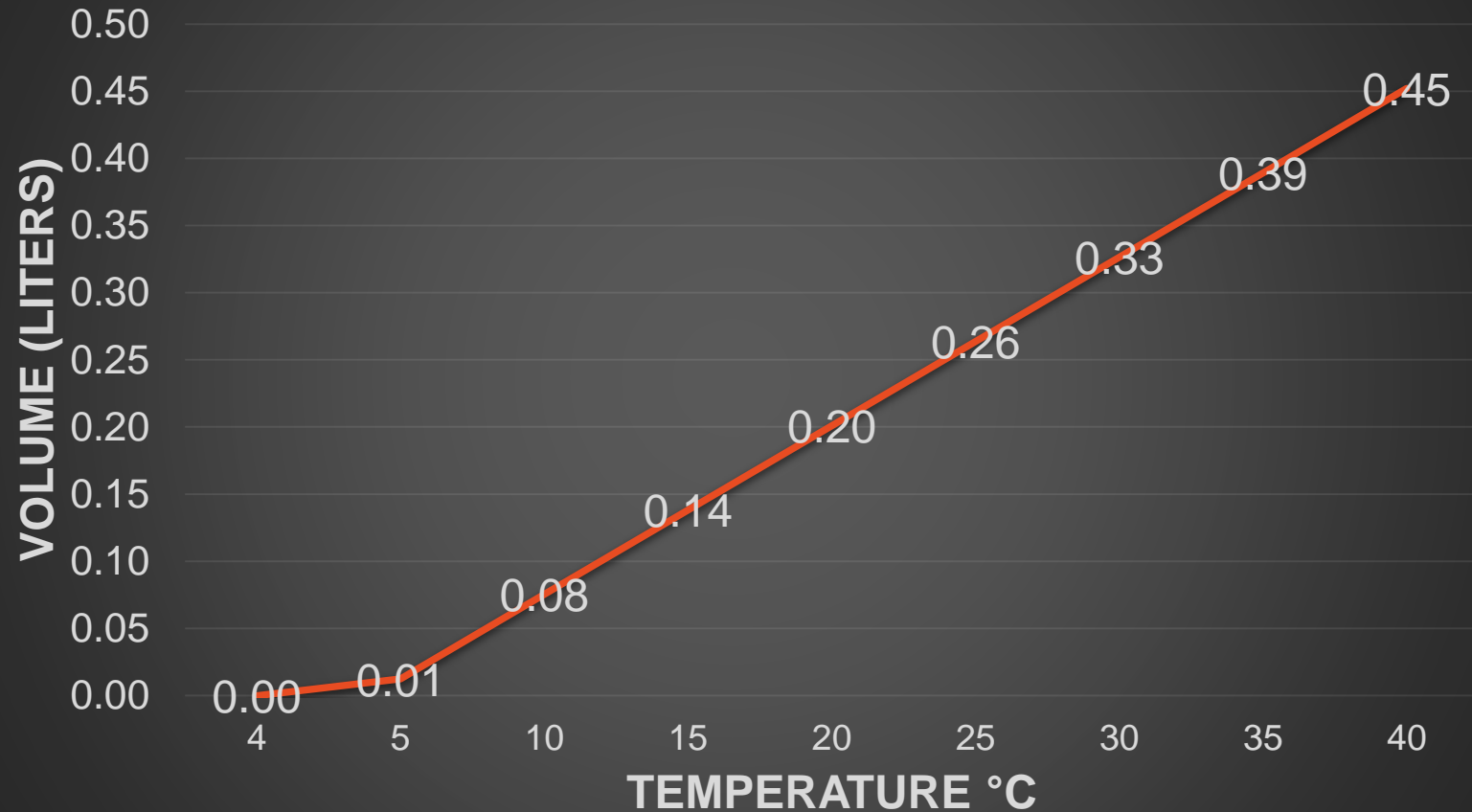

Over-filling

- Thermal Expansion of Liquid = hydraulic pressure
Leave head space! Your kegs are designed to hold full specified volume of beer plus head space.

- **Best method:** fill by metered volume or by weight
- **Second best method:** fill upright to overflow through coupler with keg propped on an angle

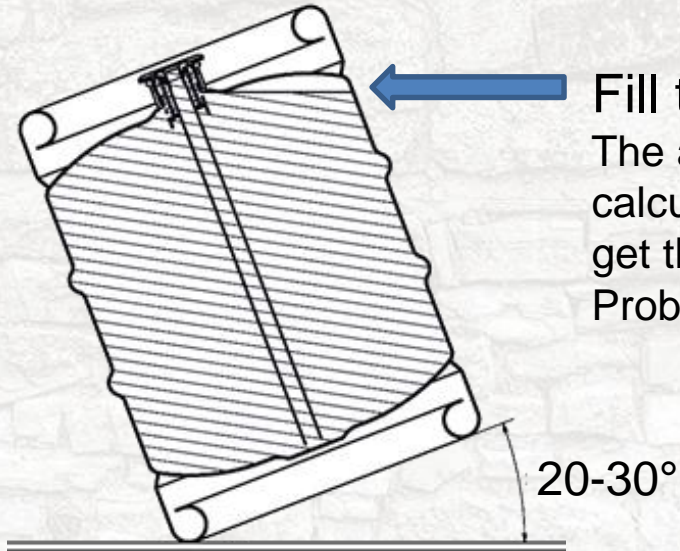

Fill to here!

The angle will need to be calculated for different kegs to get the correct volume of fill. Probably in the range of 20-30°

Typical Head space:

20L = .4L

30L = .6L

50L = .8L

½ Bbl = 1.0L

- **Worst method:** fill upright, flat on the floor (valve end up) to overflow from coupler resulting in keg that is 100% filled with beer – over-filled

Damage to Valves from Over-pressurization

Likely from freezing or thermal expansion from temperature changes and a lack of proper headspace

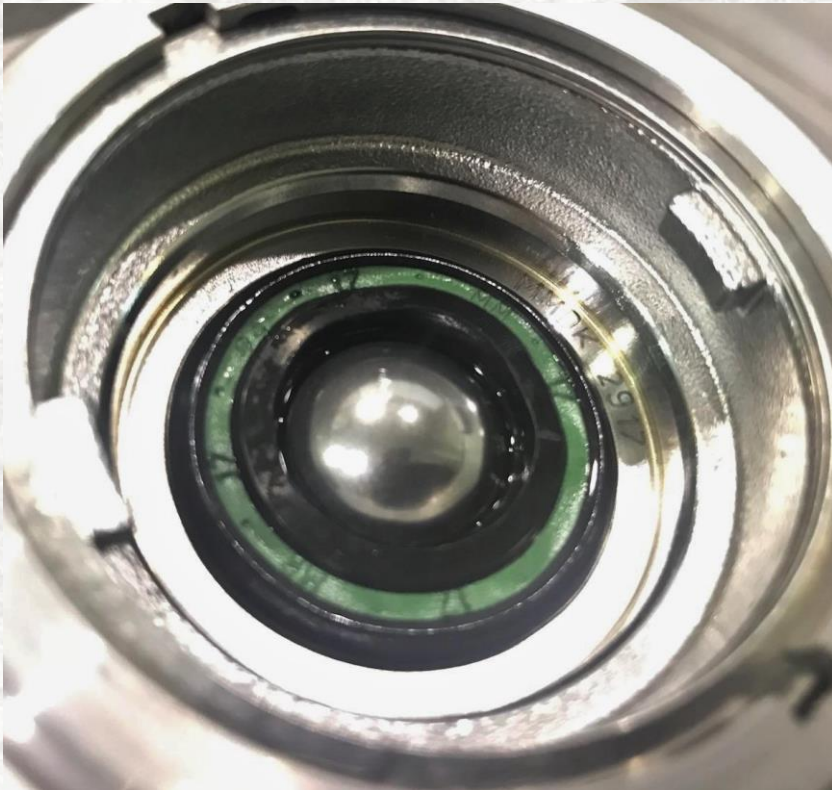

Note deformation of colored date ring



Poppet pushing through CO₂ valve

Extreme Over-pressurization

Due to over-filling and strong hydraulic force

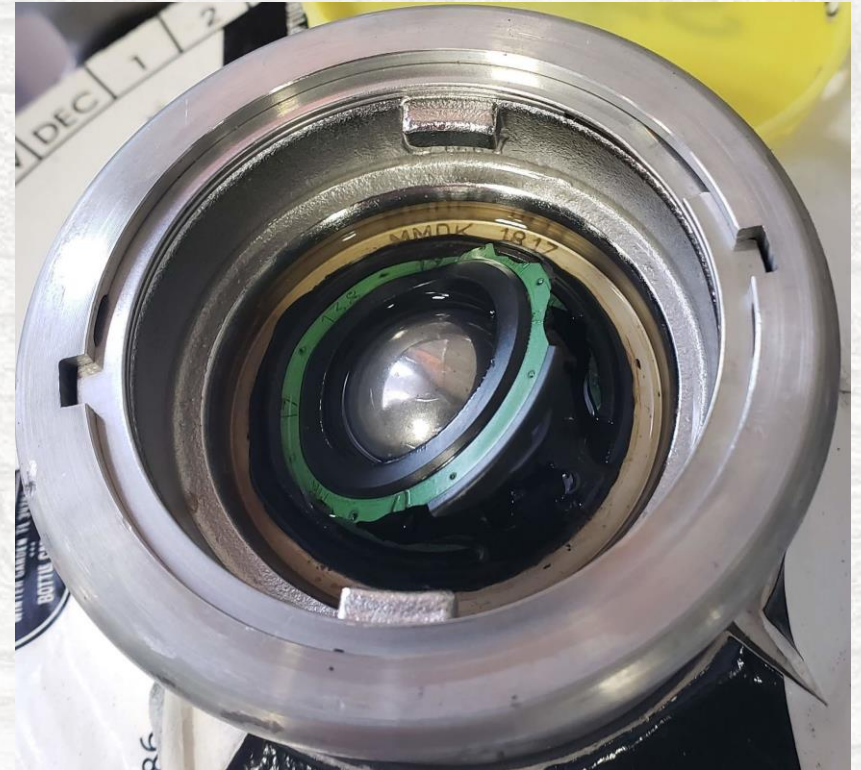

Valve Failure

1. Beer Leakers

Symptoms - Beer leaks from the interface between the beer valve (ball or poppet) and the CO₂ Valve, usually due to damage to either valve in the form of cuts, gouges, or dry rot.

In-market causes - Often related to damaged or carelessly used keg couplers. Couplers with burrs or sharp edges on the beer probe can cause damage to both beer and CO₂ valves. Damage is even worse when couplers are carelessly or improperly engaged.

In-brewery causes - Damaged couplers, poorly designed or maintained keg wash/fill equipment which may impact, cut, or gouge valve parts, and overfilled kegs with little or no headspace.

Remedies - Typically involve disassembly of the spear and replacement of the damaged components, requiring special tools and training, or simply replacing the entire spear as a unit.

Prevention - Good design and maintenance of draught packaging and dispense equipment, and observance of proper fill levels.

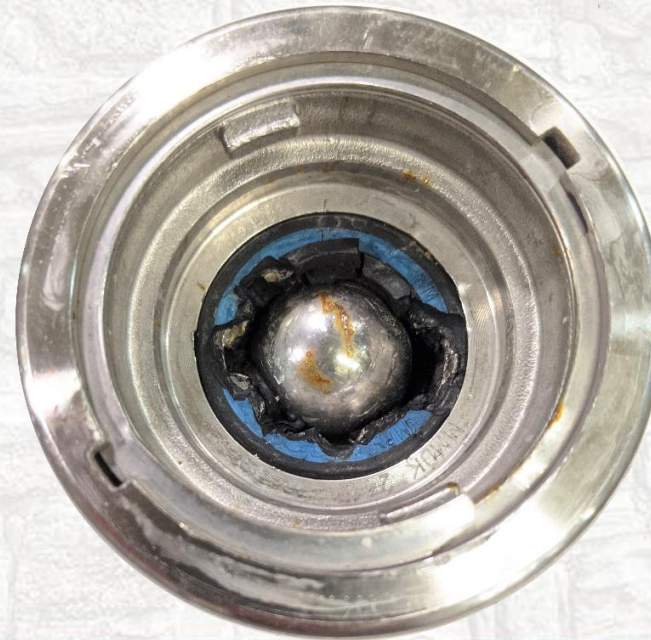

Valve Failure

2. CO₂ Leakers

Symptoms - Gas leaks around the gas sealing surface at the outer diameter of the CO₂ valve. (fig 1)

Causes – The most common are foreign objects stuck in the interface between the CO₂ valve and the spear body (fig 2). These objects include dry hops, splinters & char from barrels, and scrubby pad threads & brush bristles from manual cleaning of the keg well. Sometimes overfilling, over-pressurization, or improper maintenance techniques can cause damage to the CO₂ valve resulting in gas leaks also (fig 3).

Remedies - Can often be as simple as flushing the foreign material out of the sealing area by sending the keg through the washer for an extra cycle or two.

Stubbornly lodged objects or damage to the CO₂ valve may require disassembly of the spear or replacement of the CO₂ valve.

In rare cases of damage to the valve body itself, it may be necessary to replace the entire spear.

Prevention - Practice proper filling and cleaning techniques, and make efforts to exclude foreign material from beer entering the kegs.



Figure 2

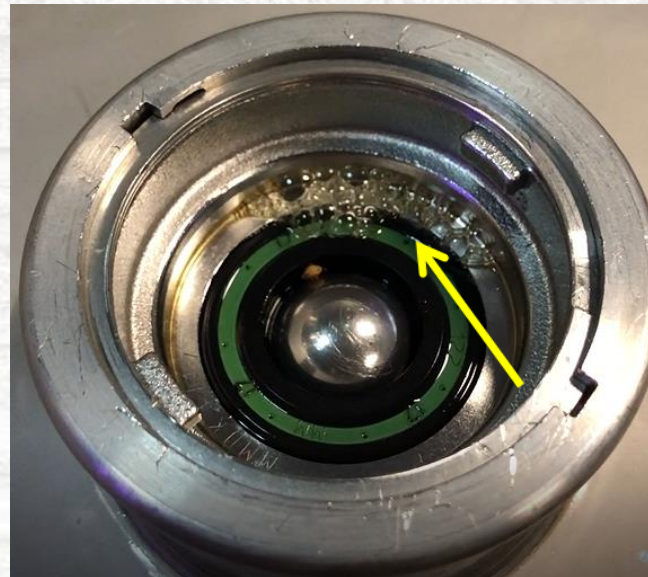

Figure 1



Figure 3

Valve Failure

3. Foamer Kegs

Symptoms - Beer foams at dispense without any identifiable cause associated with the dispense system. The raised rim around the inside diameter of the CO₂ valve is damaged, allowing gas to pass from the gas passage over into the beer stream.

Causes - Similar to those for beer leakers. Kegs that have been stored with extended exposure to the sun are also prone to this type of failure due to cracking and dry rot. These problems will only be identified by observing valve damage during visual inspection at the brewery or by poor pouring performance in the market.

Remedies - Replacement of damaged CO₂ valves

Prevention is the critical issue here, involving proper identification of the problem before the keg leaves the brewery. This can only be accomplished by good training for keg technicians to identify any damage and pull kegs out of service before they can return to market.



Cracked rubber from UV exposure (sunlight)



Impact damage to raised rim on CO₂ Valve

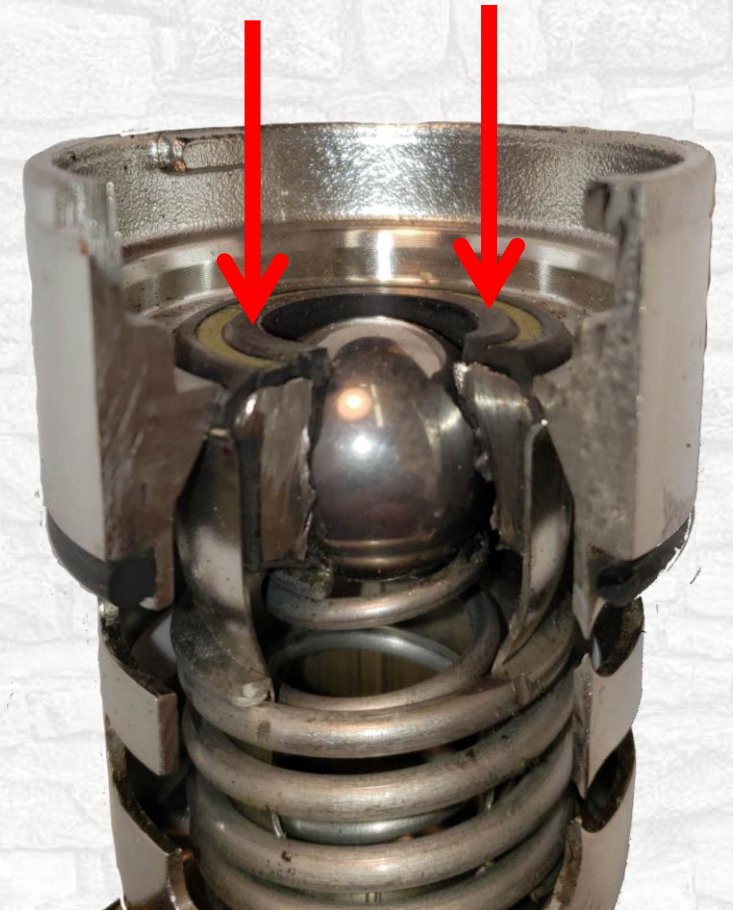

Valve Failure

4. Neck Leaks

Symptoms - Beer or CO₂ seeping out at the top of the neck. This is a fairly rare occurrence in drop-in spears. It is much more common in threaded spears.

Causes - The O-ring (drop-in spears) or sealing ring (threaded spears), which seals the spear into the keg neck is degraded, damaged, or spear is loose.

Drop-in spears - Over-compression of the O-ring during installation or failure to wet the O-ring prior to installation, which results in damage to the seal.

Threaded spears - Leaks can occur as a result of insufficient application of torque during installation (~55 ft/lbs), failure to wet the sealing ring prior to installation, failure to periodically re-torque the spears (~35 ft/lbs), and loosening of the threaded connection caused by tampering or attempts to remove couplers which have become stuck in the spear.

Prevention - Wetting of all O-rings and sealing rings prior to installation, tightening and retightening threaded spears to specified torque settings.



Torque Wrench Adapter
for Threaded Spears

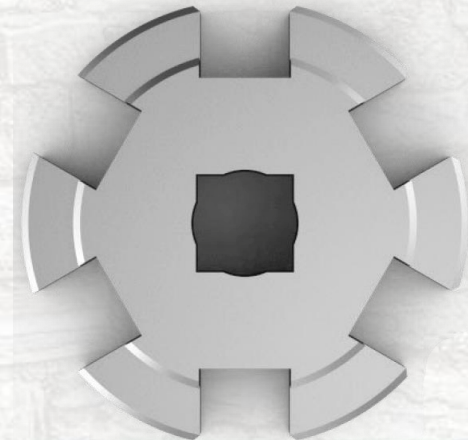

Valve Failure

5. Delamination of the CO₂ Valve

Symptoms - Rubber deteriorates and cracks, separating from the metal core inside of the valve, resulting in areas which may be uncleanable and harbor contaminants. Early symptoms can be difficult to identify but operators should look for flaps of rubber (fig. 1), or bubbled/swollen rubber (fig. 2). Valves with advanced delamination (fig.3) will often fail to drain when inverted and placed on the keg washer

Causes - This is most often found on very old valves (10+ years), valves that have been subjected to excessive steam or chemicals during cleaning and sanitation, or stored in exposure to UV (sunlight). This failure can often be identified by a failure of kegs to drain properly on the keg washer. Visual signs of delamination are shown, but may not be evident until well after these have become a QA/QC risk.

Remedies - Replacement of the CO₂ valve is required once this damage has occurred.

Prevention - The best way to avoid this damage is a preventative maintenance program, which ensures valves are replaced in a timely fashion, prior to delamination due to old age. It is also important to frequently check the temperatures and concentrations of steam and chemicals in your keg line to ensure they are not causing premature wear to the CO₂ valves, and to protect valves from prolonged exposure to sunlight.

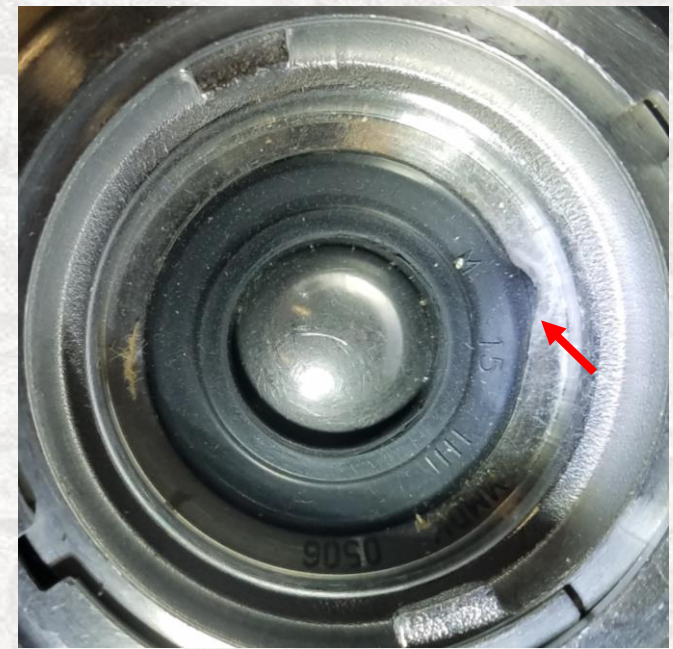

Figure 1



Figure 2



Figure 3

Valve Failure

6. “Seeper” Kegs

Weakened springs in the valves cause the beer valve (ball or poppet) to seat poorly or bounce when the kegs are moved. These kegs will leak/seep/”burp” small amounts of beer into the well unpredictably.

Causes - Springs are weakened prematurely due to over-stroking (over-compression) caused by poorly designed or misadjusted wash probes, through normal wear-and-tear, or due to spears being rebuilt using worn springs.

Remedies - Replace damaged or worn springs

Prevention - Make sure that your keg washer is equipped with wash probes designed to stroke the beer and CO2 valves the correct distances and that the machine is properly adjusted for stroke.

Rebuild spears as part of a preventive maintenance program which includes replacement of worn or damaged springs. A partial rebuild may lead to difficult to track nuisance seepage.

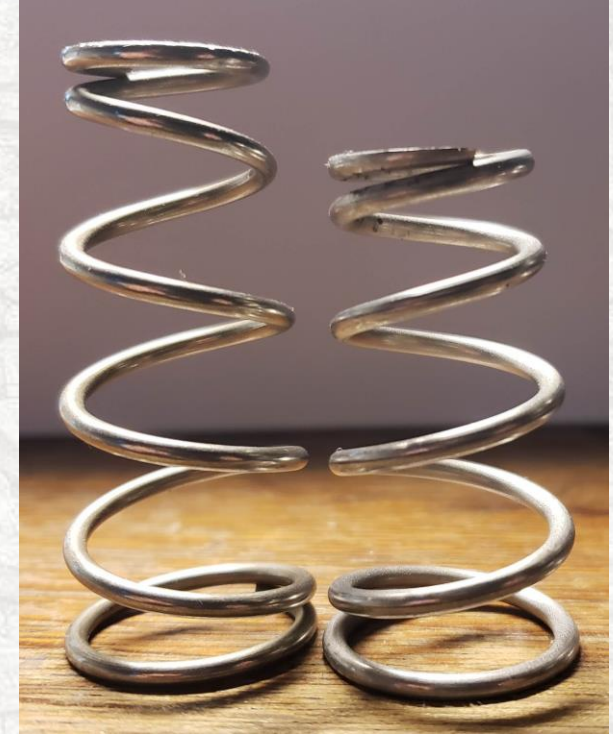

Washer/Filler Interface Manual/Semi Auto Keg Washers

- Less prone to damaging valves
- Special wash/fill coupler required with:
 - No check valves
 - 100% stainless steel construction
 - Larger bore gas port for drainage
 - No pressure relief valve on gas port
 - (easiest way to recognize)
- Check condition of probe at the beginning of every shift to assure there are no sharp edges or burrs.



Washer/Filler Interface, Fully Automatic Keg Washers

- Damaged probe
- Keg neck “bent”
- Keg neck poorly centered
- Foreign object

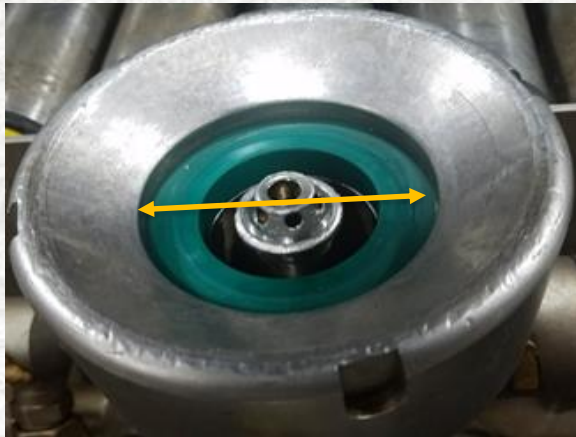

Check diameter of
Centering Cones.
Replace at >64.2mm



Critical Dimensions for Wash/Fill Probes

This portion of the probe depresses the beer valve (ball/poppet). The proper stroke is 8 mm. **A longer stroke can damage the beer spring and result in restricted flow**

This “shoulder” on the probe depresses the CO2 Valve (rubber seal).

If your probes are not equipped with “wings” for a positive stop, you can measure the distance from the “shoulder” (described in the box above) to the gasket on your keg washer centering cone that seals against the keg neck, with the probe in the engaged position, to determine the overall stroke of the CO2 Valve. A measurement of 23mm indicates ~6mm of stroke on the CO2 valve, the maximum suggested.

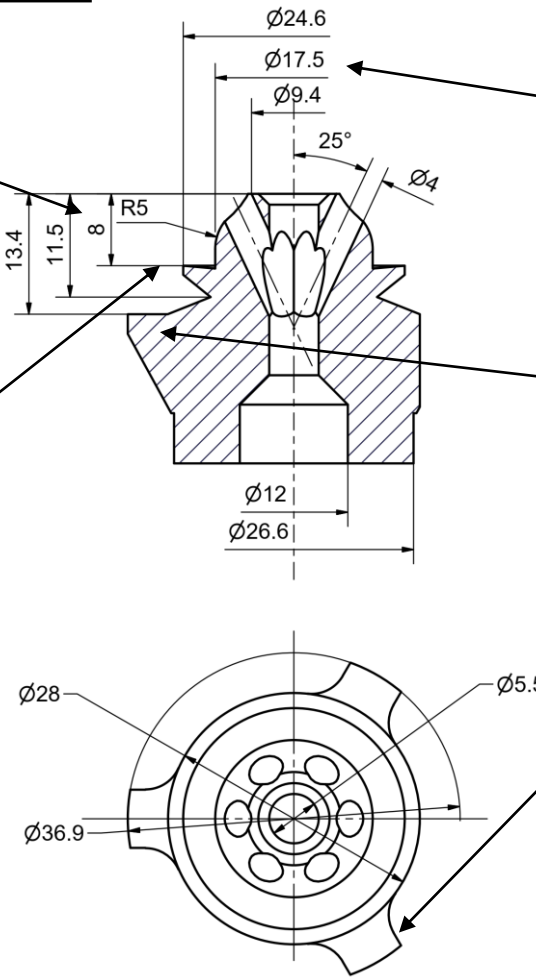

17.5 mm OD provides support for the 17.8 mm opening in the CO2 valve to prevent tearing of the seal under heat and pressure encountered during wash cycles

If your probe is equipped with these “wings” to provide a positive stop against the inside of the spear and prevent over-stroking of the CO2 valve, a distance of 13.4 mm from these wings to the top of the probe, combined with a 8 mm stroke on the beer valve will assure that the CO2 valve is not inserted too far into the keg. **Over-stroke of the CO2 valve damages the CO2 spring and reduces the gap between the downtube and the bottom of the keg, dramatically affecting cleaning performance.**

How to Avoid Valve Damage

1. Ideal Keg Packaging Line Design
2. Maintain Your Keg Packaging Line
3. Maintain Your Keg Valves
 - Pull spears for inspection on a regular basis
 - Rebuild spears after about **7-8 years** of service
 - Possibly sooner if your valves are abused!
 - **ALWAYS use a new double circlip (never reuse these)**
 - ALWAYS match valve parts to the valve manufacturer
 - Send spears out for 3rd party refurbishment or rebuild in-house
 - Request service training from your keg or valve supplier

How to Avoid Valve Damage

- 4. Inspect All Kegs Returned to the Brewery
 - Check for bent necks, foreign objects, and damaged CO2 valves (foamer kegs)
- 5. Repair Every “Bad” Keg
 - What does “bad” mean? Sensory problem, flat beer, foamer, beer leaker, neck leaker, bent neck, leaking weld, crushed chime, freeze damage, etc.
 - Kegs returned as “bad” should be quarantined, sorted and logged, rebuild every one!
- 6. Don’t Overfill Your Kegs

How to Avoid Valve Damage

- 7. Clear all foreign materials
 - Potential damage to the CO₂ Valve as these items are ground in by the wash probes or pushed into the keg to emerge in someone's glass later. Ouch!



Fundamentals of Keg Safety

- **All** employees handling kegs must be trained in how to spot potential hazards, such as circlips that are missing or damaged.
- Kegs must always be depressurized before removing a circlip or spear.
 - Extra care must be taken if there is any evidence of damage to or tampering with the circlip
 - Depressurization must be completed/confirmed by the person who will be servicing the keg.
 - Keg must be depressurized immediately before service is performed. Remnant beer and temperature changes can re-pressurize a previously de-pressurized keg.
- A new circlip of the best quality and design should be used every time a spear is installed and should never be forced into position.
- Acquire service tools specific to the spear/neck type and manufacturer.
- All employees who service kegs should be fully trained in the safe use of the proper tools and supported with detailed SOPs

Use the Proper Tools – Safely!

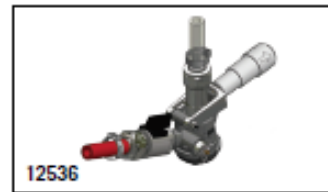
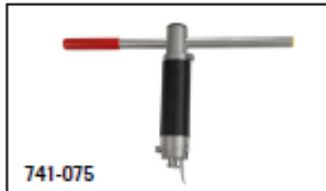
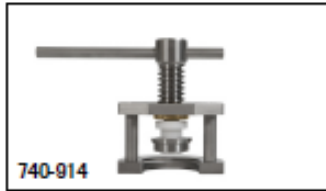

Make Sure Your Circlips Are Safely Installed

Poor placement of the end of the circlip in the neck notch, making it vulnerable to tampering or to snagging on a coupler or bar towel. Set aside for replacement.



Always be on the lookout for bent or otherwise damaged circlips that may indicate **tampering** has occurred. Damaged circlips should be replaced by a trained technician before the keg is washed or filled



Partially Removed Circlips

USE EXTREME CAUTION!!

Be on the watch for any sign that a circlip is not fully seated in the keg neck. When discovered:

- Always keep out to the path of ejection!
- Quarantine keg in a safe area and notify a qualified service person immediately.
- Never assume this means the keg is not fully pressurized.
- Depressurize keg by depressing the beer valve with a long pole such as a broom handle which allows the operator to keep out of the path of ejection.



What is the end result?

*A multi-level program of
Quality Control, and Quality and
Safety Assurance to achieve the ultimate goal:*

Customer Satisfaction

for your Draught Packaged Beer

**Thank you for
your interest
and attention!**



MICRO MATIC – THE TRUSTED
LEADER IN KEG SPEAR TECHNOLOGY

Contact Steve Bradt
for sales and
technical support
sbradt@micro-matic.com
785.766.1921

